



2022

ACCESSORY STRUCTURE GUIDE



TOWNSHIP OF MANITOUWADGE

1 Mississauga Dr. | PO Box 910 | Manitowadge, ON | P0T 2C0

1. ZONING

Zoning by-laws regulate where the shed, garage or other accessory building can be placed, including how close to the lot line you can place the building and, in some cases, how much of the property can be covered by a building. A Building Permit cannot be issued if the proposed construction does not comply with the Zoning By-law for your property. Contact the Township's Planning Administrator and find out what the zoning by-law for your property says, before you finalize the design of your building.

If the building does not comply with the property's zoning by-law, please contact the Township's Planning Administrator before proceeding to Step 2. You may have the opportunity to apply for a variance to the Zoning By-Law.

2. DETERMINING IF A BUILDING PERMIT IS REQUIRED

In most cases it is against the law to begin construction or demolition of a building, without having a valid permit. The Building Inspector is available throughout the permit process to assist you with your application and answer any questions you may have. If the size of the proposed shed or garage is greater than 161 ft², then you need a Building Permit. This includes shed or garage kits purchased from a retail outlet. If you're not sure, please call our Building Inspector at 807.826.3227 ext. 238.

Even if a Building Permit is not required, the zoning requirements for your property still apply. Refer to Step 1 before you proceed any further.

3. PREPARE A SITE PLAN DRAWING

Prepare a site plan, showing the location and size of the proposed building and all other structures on the property. (Refer to Figure 1 – Sample Site Plan Drawing). Keep in mind the setback requirements and lot coverage restrictions required by the Zoning By-law for your property (Step 1). You can use a survey or previous site plan drawing of the property to sketch an outline of the proposed building. This can be drawn by hand (with a ruler and permanent ink) or by computer software. You must show:

- scale
- all dimensions of the building including length, width, height and area
- the distance from the edges of the building to the lot lines
- the location and size of any other existing buildings on the property
- all dimensions listed in metric units
- direction arrow
- all overhead electrical wires / conductors

If a survey is required, contact the Building Department, to see if we have one on file. You may

obtain a lot survey through the Ontario Land Titles office at <https://www.onland.ca/ui/>.

4. PREPARE CONSTRUCTION DRAWINGS

Prepare construction drawings for the building. If you're not familiar with OBC requirements, consider hiring a qualified designer to help design your shed or garage.

If your shed or garage is constructed from a prefabricated kit, you must submit the manufacturer's floor plan and construction details.

As a minimum, construction drawings must include

- Site Plan
- Plan and Section drawings
- Sizing Tables and Notes
- Framing details
- Brick veneer details, if applicable
- Solid Masonry details, if applicable
- Elevation drawings
- All dimensions must be listed in metric units

5. ASSEMBLE DRAWINGS AND APPLY FOR A PERMIT

A Building Permit is issued to the owner of the property, or the authorized agent of the owner, i.e., the contractor. Your designer or contractor can also apply for the permit on your behalf. It is, however, the responsibility of the property owner to ensure compliance with all building requirements.

Building Permit applications are accepted at the Township Office, Monday through Thursday, between the hours of 1:00 pm and 4:00 pm. You can also email your application directly to the Building Inspector at buildingpermits@manitouwadge.ca or by fax at 807-826-4592.

Bring along two (2) copies of all the drawings, including the site plan and all construction drawings (See Step 4). These must be submitted at the time of application along with the permit fee.

If our property records do not show you as the owner of the property, (perhaps you just recently moved to this property?) you, or your contractor, will be asked to provide a copy of the deed to the property, and some personal ID to confirm the ownership.

Currently, plans review for a shed or garage will take approximately 10 business days. You will be called if we have any further questions, or, as soon as the Building Permit has been issued. You or your contractor must pick up the issued Building Permit together with a set of the approved construction drawings, before you begin construction.

The Building Permit must be displayed somewhere on the property, where it can easily be seen by the general public, like a window, front door, attached to a post in the yard. The approved drawings must be available on site at all times, during the construction of the building.

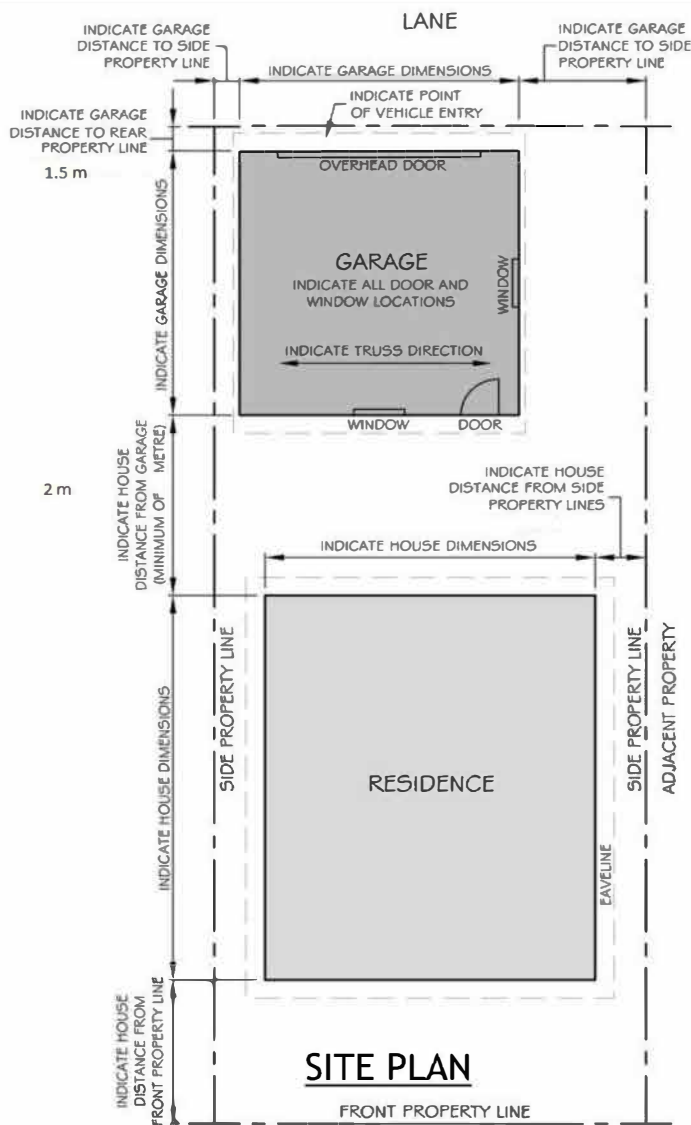
6. BOOK YOUR INSPECTION

Certain inspections are required on site, once construction has begun. The Building Inspector will advise you of all required inspections and how to book them. The Building Permit process is not considered 'closed', until all inspections have been signed off by the Township's Building Inspector.


Typically, inspections for a shed or garage include:

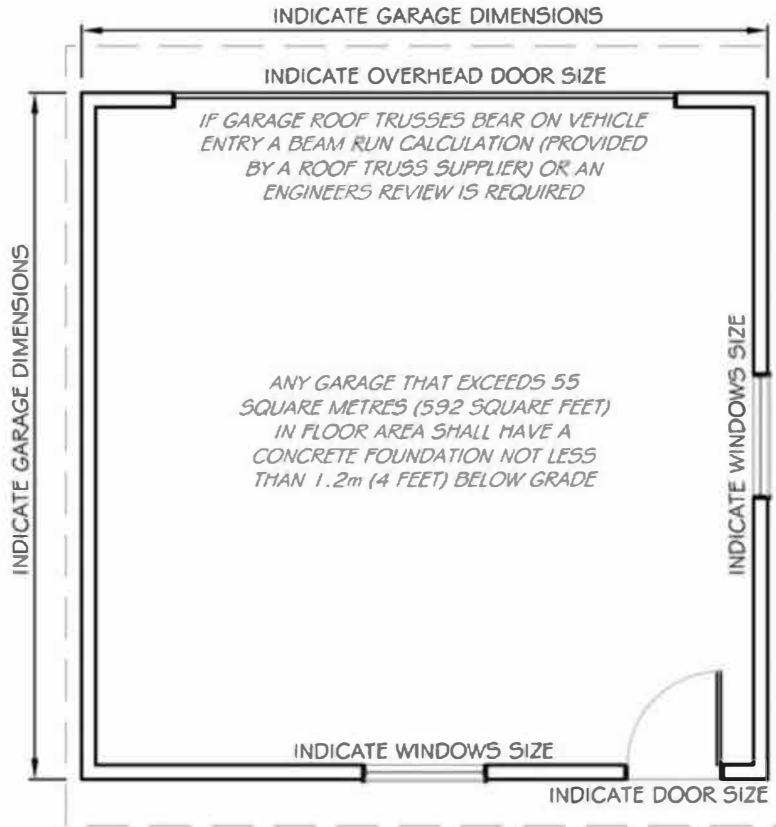
- Inspecting the footings prior to pouring concrete
- Inspection of the building (all frame elements must be visible for inspection)
- Final inspection

7. SAMPLE DRAWINGS

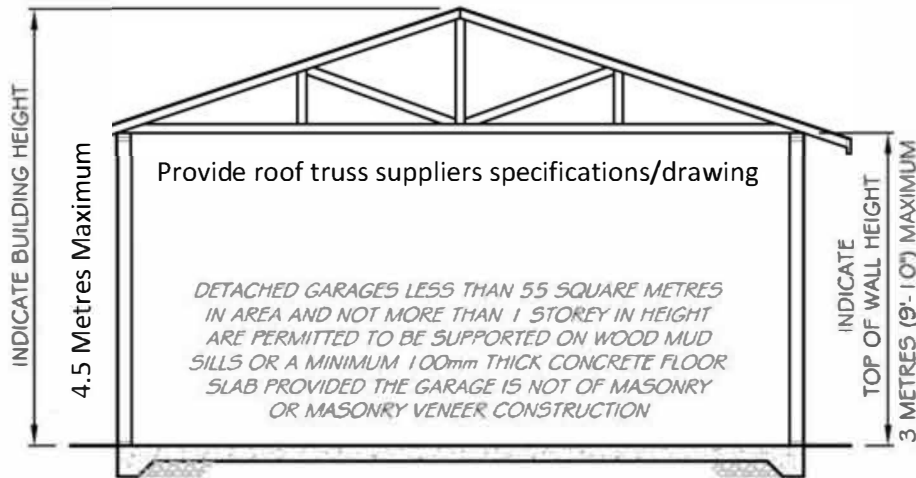


****Also show overhead electrical conductors including service line.**

	SAMPLE SITE PLAN	DATE: MARCH 3, 2016
	ADDRESS: 123 FOUR ST NW	SCALE: 1 : 200



FLOOR PLAN

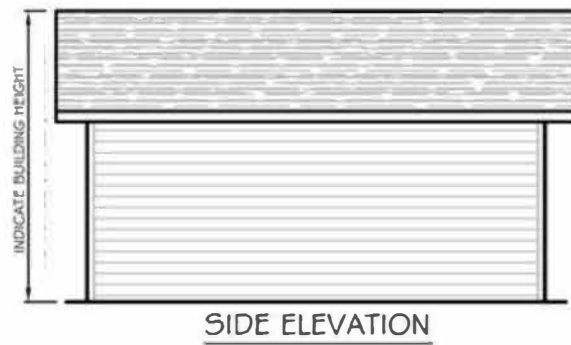
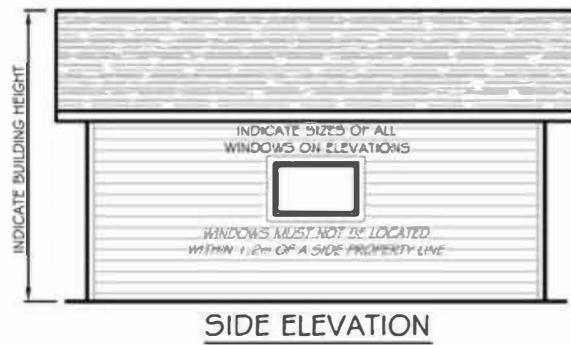
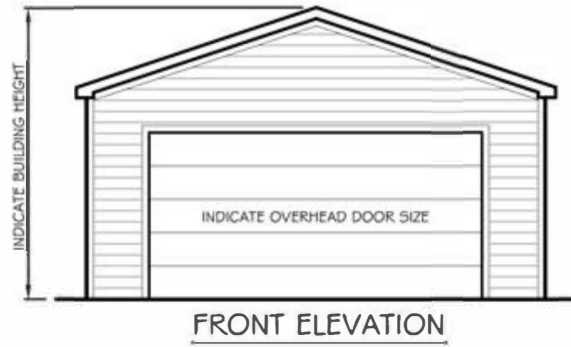


CROSS SECTION

**If garage is over 55 m², engineered slab is required.

	SAMPLE DRAWINGS	DATE: MARCH 3, 2016
	ADDRESS: 123 FOUR ST NW	SCALE: $\frac{3}{16}'' = 1'$

Figure 2 - Sample Floor Plan and Cross-Section



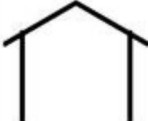
	SAMPLE ELEVATIONS	DATE: MARCH 3, 2016
	ADDRESS: 123 FOUR ST NW	SCALE: $\frac{3}{16}'' = 1'$

Figure 3 - Sample Elevation Drawings

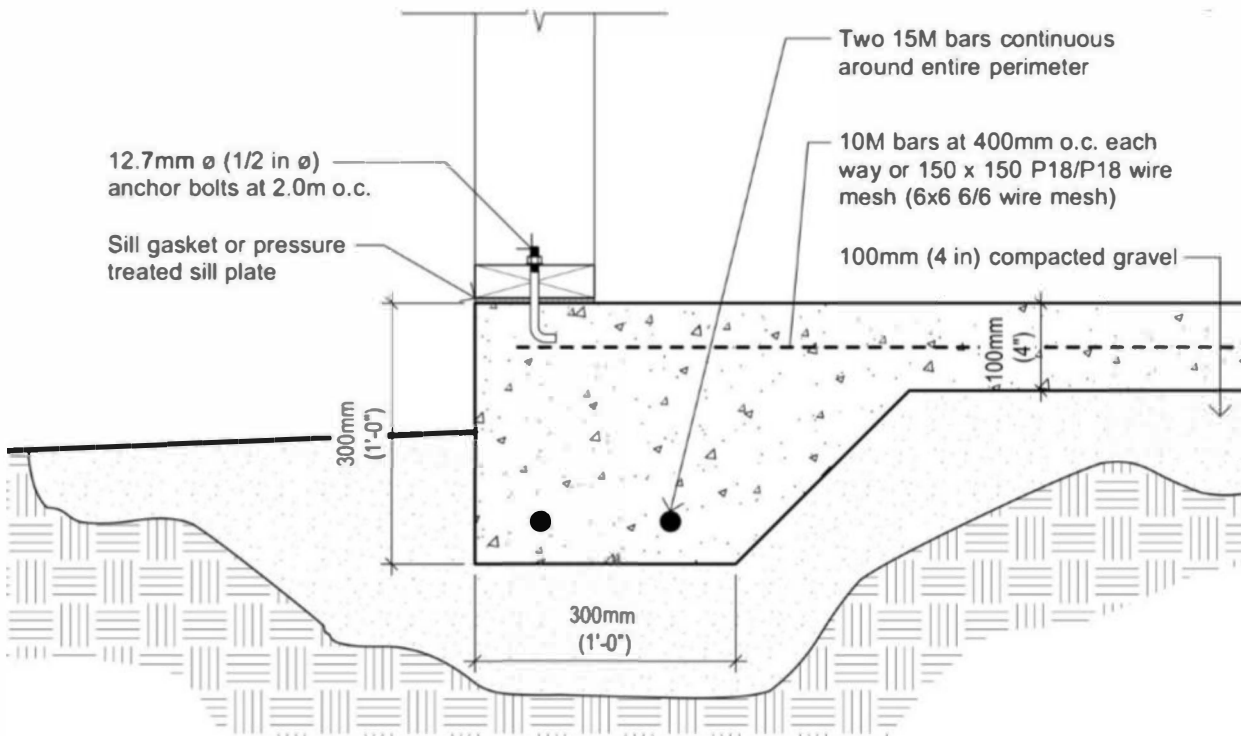
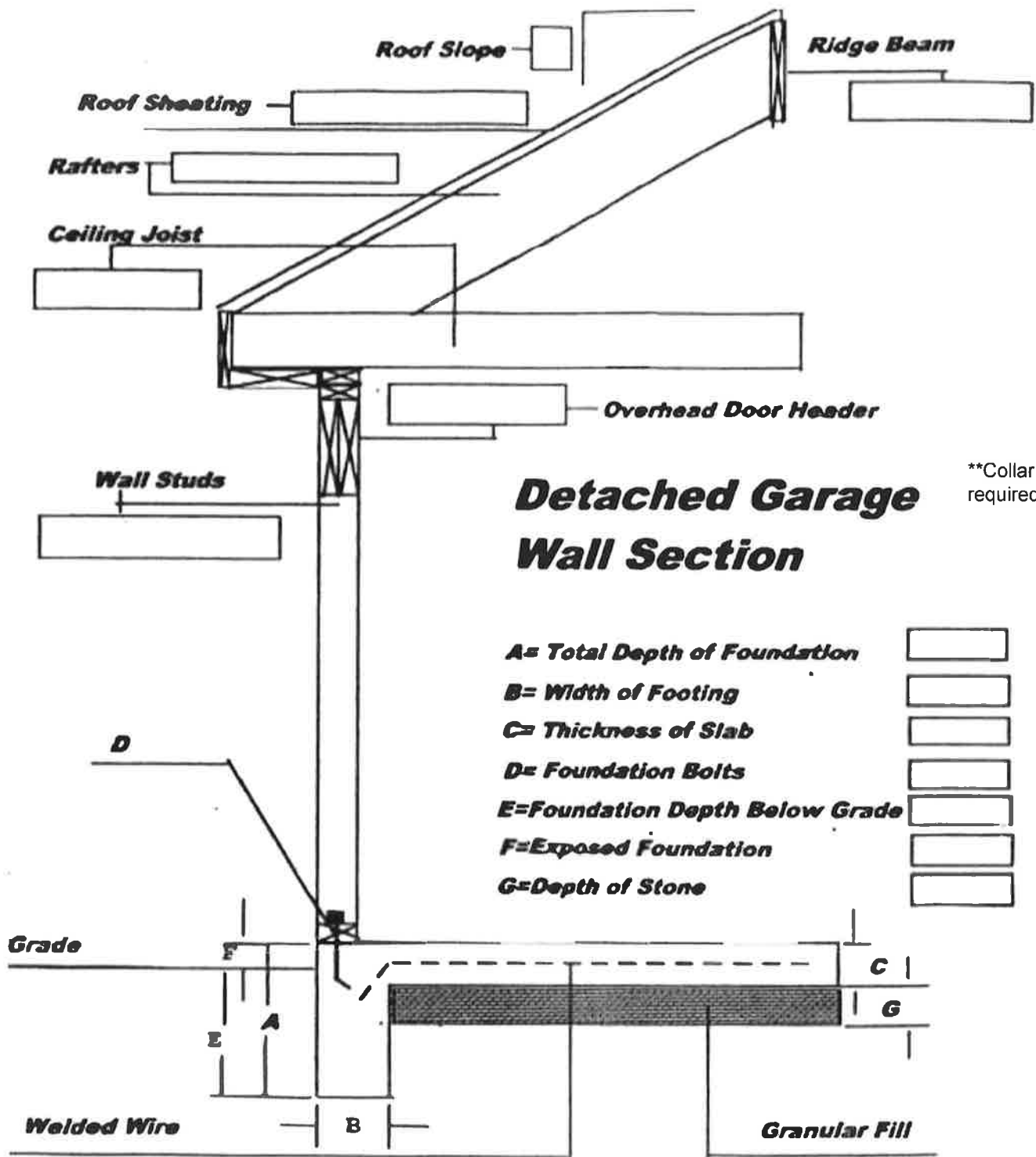


Figure 4 - Sample Monolithic Slab

**Reinforcing steel only required for slabs over 55 m²

NOTE: Concrete used for all detached garage or shed foundation slabs must have a minimum compressive strength of 32 MPa (4600 psi) after 28 days and must have air entrainment of 5% to 8%.

NOTE: If your structure is over 55m², the foundation slab **must** be designed by a professional engineer.



Detached Garage Wall Section

**Collar ties required.

- A= Total Depth of Foundation**
- B= Width of Footing**
- C= Thickness of Slab**
- D= Foundation Bolts**
- E= Foundation Depth Below Grade**
- F= Exposed Foundation**
- G= Depth of Stone**

Detached Garage

FAQs

Who is allowed to design a residential shed or garage?

The homeowner or person who owns the property is allowed to design the shed or garage. If the home/property owner is not preparing the shed or garage design, consider having a qualified designer with a minimum qualification of “BCIN House” prepare the design. A form called ‘Schedule 1: Designer Information’ (available at Town Hall), must be completed and submitted along with the permit application.

Who is allowed to construct a residential shed or garage?

Anyone is allowed to construct a shed or garage once a building permit has been issued to the home/property owner.

It is, however, the responsibility of the home/property owner to ensure that:

- a Building Permit has been obtained and posted in a visible location
- the work complies with the Ontario Building Code
- the required building inspections have been scheduled and signed off

The Building Permit process can only be ‘closed’, once the construction is deemed complete by the Township’s Building Inspector.

Do I need a building permit to reconstruct or repair the same size and style of shed or garage I already have?

Yes. Even if you are reconstructing or repairing the same size shed or garage, a building permit may be required. If the shed or garage you are repairing or replacing was constructed prior to the current, amended version of the OBC, there may be new requirements for the construction that must be met.

Constructing, repairing or reconstructing without the authority of a building permit may result in extra fees for Building Code Act Orders or extra fees for the Building Permit application. It may also result in extra costs for additional materials, or for a professional engineer’s design (P.Eng review) being required in order to bring the shed or garage in to compliance with the current OBC.

What size of shed or garage can I construct on my property?

See Step 1 of the Township of Manitowadge’s, Accessory Structure Guide. The Township will review the Zoning By-law for your property and advise you on the required distances from lot lines, permitted height of shed or garage, and lot coverage maximums.

What building materials and construction methods do I want to use to build my shed or garage?

It’s important, early in the process, to consider the building materials and construction methods you intend to use when constructing your new building. The type of material you choose may have different requirements for construction under the OBC. Knowing how your materials work and perform may help in eliminating delays in getting your approved Building Permit and reduce frustrations during construction.

If you are considering any new or innovative building materials or construction practices, our Building Services staff will help you determine how to choose materials and methods that comply with the OBC.

Graded lumber is required as per Building Code.

What should I consider before designing the shed or garage?

- What is the proposed location of the shed, garage or accessory building?
- What type of foundation system will be used? (slab on grade, mudsill, etc.)
- Will the shed or garage be connected to the house?
- Will there be plumbing?
- Is electrical (lights) required by code?

Can I install plumbing in my shed or garage?

Yes, a water line is permitted in a shed or garage. Plumbing drawings must be submitted for review if you intend to do this. Other design requirements may be asked for as a result of plumbing.

Why should I go to the trouble of getting a Building Permit for my shed or garage?

The Building Code Act requires it. This is legislated.

Sheds and garages share many of the same structural requirements as buildings like your house. They are also subjected to wind, rain and snow loads, and variations in temperature.

Sheds and garages can fail slowly over time, resulting in costly damage, and potential injury, loss of life, or personal liability if the shed or garage was constructed improperly or without a Building Permit.

What can I do to make sure my construction site is safe before I build my shed or garage?

- **Before you dig...**Call Ontario One Call and make an appointment to locate underground utilities such as hydro and water/sewer lines. If you're on septic, be sure you know where the septic tank is located. Visit <https://www.ontarioonecall.ca/contact-us/> or call toll free at 1.800.400.2255.
- Be aware of any existing overhead wires or hydro lines.
- Check if any windows or doors will be obstructed by the new construction.
- Make sure all your construction equipment is in good order.
- Wear personal protective gear such as gloves, safety goggles, sturdy closed toe footwear (or safety boots). For more health and safety regulations, visit the Ministry of Labour website at www.ontario.ca/page/ministry-labour.
- Reduce confusion on the job site by developing a simple construction plan, then organize your construction materials accordingly. Be sure to store all materials and tools in a safe place when not in use.

Contact Information:

For Zoning Inquiries:

Joleen Keough, Clerk / Planning Administrator

Phone: 807-826-3227 x 223

Email: clerk@manitouwadge.ca

For Building Inspection Services:

Darren MacKenzie, Director of Public Works and Facilities

Phone: 807-826-3227 x 238

Email: buildingpermits@manitouwadge.ca

Website:

www.manitouwadge.ca